

**CIRCUITS FOR POWER FACTOR CORRECTION  
WITH REGARDS TO MAINS FILTERING**

by J. M. Bourgeois

**1. INTRODUCTION**

The new European Norms and the international standard will impose a limit on the harmonic content of the input current of mains supplied equipment. In practice this will require the addition of a Power Factor Corrector (PFC) at the input of many types of mains operated electronic equipment, for example electronic lamp ballasts, TV power supplies and motor drives. A correctly designed PFC draws a sinusoidal input current from the mains supply, in phase with the mains voltage. It may also provide additional functions, such as automatic mains voltage selection and a regulation of the voltage supplied to the attached equipment.

Size and cost optimization of PFCs must include the RFI filter on the input, which prevents interference being fed back to the mains. The addition of the PFC represents another switching stage in the system, meaning that larger amount of high frequency noise is applied to the mains than with a conventional rectifier/capacitor front end, and so additional RFI filtering is required. The amount of filtering needed can be minimized by choosing suitable modulation techniques and mode of operation of the PFC.

**1.1 Basic principles of operation**

A power factor corrector is basically a AC to DC converter, and is usually based on an SMPS structure. The basic functional blocks of a Power Factor Corrector are shown in figure 1.

A standard SMPS uses Pulse Width Modulation (PWM) to adjust the amount of power it supplies to the attached equipment. The Pulse Width Modulator controls the power switch, which chops the dc input voltage into a train of pulses. This train of pulses is then smoothed, producing the dc output voltage. This output voltage is then compared with a voltage reference representing the voltage desired by the equipment being supplied, and the resulting voltage difference (the error voltage) is fed back to the input of the PWM, which varies the width of the pulses it supplies accordingly - if the output voltage is too high, the pulse width is reduced, and thus less power is supplied, and vice versa.

A PFC also uses this method, but adds a further element to ensure that the current it draws from the mains is sinusoidal, and remains in phase with the mains voltage. The error voltage is modulated with a signal derived from the rectified AC mains, before

**Figure 1. Block diagram of a Power Factor Corrector (PFC)**

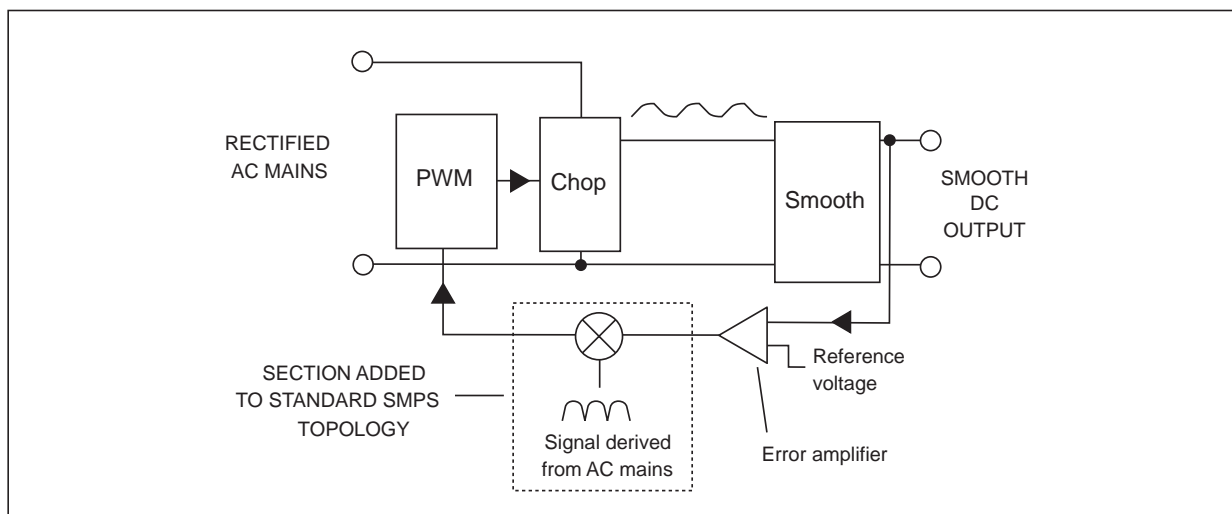

## APPLICATION NOTE

being fed to the PWM input. This means that the width of the power pulse supplied to the output device depends both on the basic error voltage and also on the instantaneous value of the mains voltage. The PFC thus draws more power from the mains when the level of the mains voltage is high, and less when it is low, which results in a reduction of the harmonics in the drawn current.

### 2. ACTIVE POWER FACTOR CORRECTOR TOPOLOGIES

Among the topologies shown in figure 2, the boost configuration operating in a continuous current mode (ie the value of the inductor at the input is calculated such that it conducts continuously throughout the switching cycle) applies the smallest amount of high frequency current to the input capacitor  $C_i$ . It is the only topology which allows the noise across the input capacitor to be reduced, which is the major factor defining the size and cost of the filter. Additionally, the boost inductor stores only a part of the transferred energy (because the mains still supplies energy during the inductor demagnetization) and so the inductor required is smaller in comparison with the other topologies.

The boost topology thus leads to the cheapest PFC solution, but does not provide either in-rush current or short circuit protection. The buck/boost topology can also be used; its advantages are that it can provide output isolation and adjustable output voltage.

This paper will take the cost as the most important consideration, and so will concentrate on the boost circuit topology.

### 3. BOOST CIRCUIT PARAMETER OPTIMIZATION

Figure 3 shows the general topology of a boost PFC. Its optimization requires careful adjustment of the following parameters:

- the value of the input capacitor  $C_i$
- the current ripple in boost inductor  $L_b$
- the parasitic capacitances of the boost inductor and the power semiconductors, including those associated with the heatsink
- the operating frequency and frequency modulation techniques.

#### 3.1 Value of input capacitor $C_i$

The noise across the input capacitor, which determines the cost of the filter, is proportional to the current ripple and inversely proportional to the capacitor value.

A value of  $3.3\mu\text{F}/\text{kW}$  is a good compromise between current distortion and noise generation.

#### 3.2 Current ripple in the boost inductor

The current ripple ( $\Delta i$ ) is a function of the input voltage ( $V_i$ ), output voltage ( $V_{\text{out}}$ ), inductor value ( $L_b$ ) and switching frequency ( $f_s$ ), and can

Figure 2. Active PFC topologies

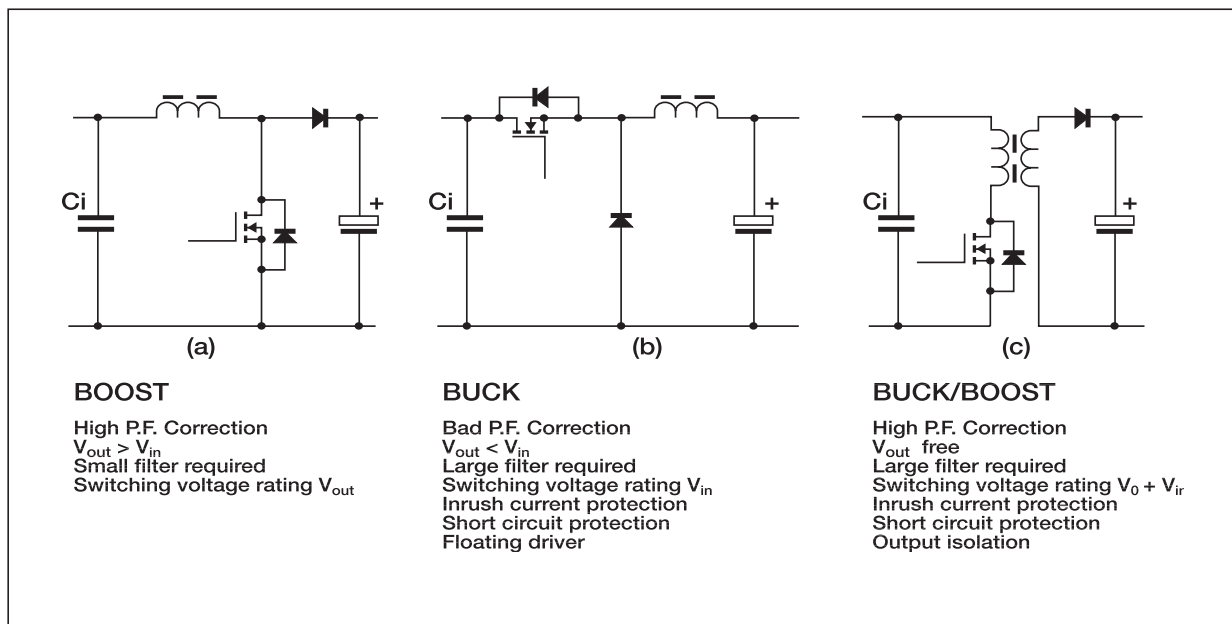
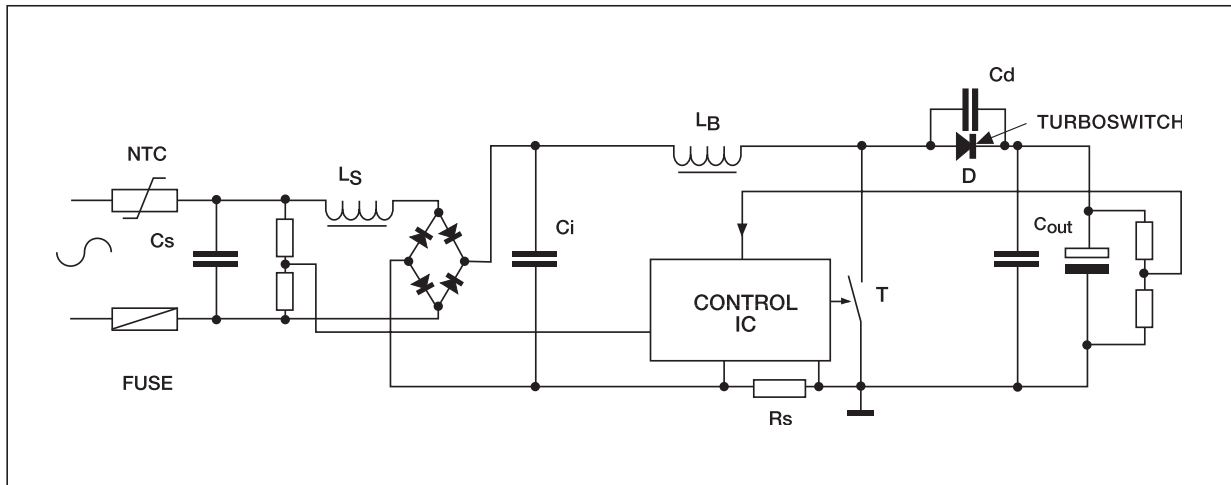

Figure 3. Basic topology of a Boost PFC



be expressed as:

$$\Delta i = \frac{(V_{out} - V_i) \cdot V_i}{F_s \cdot L_b \cdot V_{out}}$$

Typical values may be  $V_i = 300V$ ,  $V_{out} = 400V$  and  $F_s = 70kHz$ .

If the system is operating in continuous mode, a typical value of  $\Delta i$  may be 1A. This means an inductor value  $L_b = 1mH$ .

If instead the system operates in discontinuous mode,  $\Delta i$  might be 6A, in which case  $L_b = 150\mu H$ .

The inductor current waveforms represented by these ripple values are shown in figure 4.4.

Using continuous mode requires an inductance value about ten times that needed when operating in discontinuous mode; however, the low value of current ripple means that a cheap and efficient iron powder core can be used.

When operating with ripple currents larger than around 1A, the larger  $di/dt$  leads to the occurrence of skin effects and large eddy currents in an iron powder core, meaning that operation in discontinuous mode requires a more expensive ferrite core.

As the maximum possible flux density in an iron powder core is much higher than that in a ferrite core (around 1.5 Tesla in iron powder against 0.25 in ferrite), this means that the size (and hence cost) of inductor required in both cases is around the same. So, a cheaper system is achieved controlling a small current ripple by operating in continuous mode, despite the large inductor value.

### 3.3 Frequency modulation techniques

The switching frequency used can be constant or variable. If variable, the switching frequency can be controlled, or be free to vary within set limits. A circuit using variable switching frequencies can result in lower EMI and lower power losses, but the topology is harder to analyse, and the frequency characteristics sometimes more difficult to predict.

### 3.4 Choosing the switching frequency to match the power semiconductor

When using constant current ripple, increasing the switching frequency allows a reduction in the value of the boost inductor. However, increasing the switching frequency will lead to increased switching losses in the power semiconductors. In standard boost PFC circuits, conduction losses in the power switch will be lower than the switching losses, and consequently the switching frequency will be limited by the switching losses of the chosen power transistor, and the recovery losses of the boost diode.

Also, if compliance with VFG243 is required, using a switching frequency below 50kHz (where the constraints are more relaxed) will lead to a significant reduction in the cost of the filter.

Power MOSFET transistors are practical and cost effective in applications using up to 277V AC mains, with an output power of up to 3kW. The STE30NA50-DK is a perfect solution for applications in the 1 to 3kW range. This device combines a low  $R_{DS(on)}$  Power MOSFET with an ultra-fast

## APPLICATION NOTE

---

TURBOSWITCH™ diode in a low inductance and capacitance ISOTOP® package. An active snubber should be added to achieve maximum efficiency.

Above 3kW, IGBTs are more suitable due to their lower on-state losses and higher current capability. They can be used at up to 30kHz when used with a snubber.

The recovery behaviour of the diode at turn-on is responsible for the majority switching losses in PFC applications. Diodes of the new TURBOSWITCH family have a typical reverse recovery time ( $t_{rr}$ ) of 25ns at 600V with a maximum  $V_f$  of 1.5V. The TURBOSWITCH A series significantly reduces losses and is available in ratings from 5A to 60A. If an active snubber is used, the B series is better suited due to its lower forward voltage drop.

### 4. MAINS FILTERING AND RFI NORMS

This analysis has been made with reference to EN60555 (reference [1]) and VDE0871B (reference [2]) norms and design requirements.

#### 4.1. RFI Norms

The limits given by VDE0871/B are shown in figure 4.1. With increasing operating frequency, limits given by the norm decrease, while the noise measured across the normalized impedance increases (figure 4.2, 4.3). When the switching frequency is increased, the required filter attenuation is not reduced as much as one would expect. The margin between the limits and the noise is only improved by about 10dB/decade. As an example, an increase of switching frequency from 10kHz to 100kHz would improve the filter attenuation by about 10dB, but would increase the switching losses by a factor of 10.

#### 4.2 Filter optimization parameters

Because of the increase in switching losses, instead of increasing the operating frequency, it is preferable to reduce the generated noise. The noise generated across the input capacitor is proportional to the current ripple. Figure 4.4 shows possible inductor current waveforms resulting from operation a) in continuous mode and b) in discontinuous mode.

Reducing the current ripple in the boost inductor by a factor of 20 will reduce the noise by 26dB. Continuous mode operation leads to minimum noise.

Operation with variable frequency is another means of noise reduction. This causes the noise spectrum to be spread over a wide frequency range, reducing the peak amplitude of the noise and so reducing the

amount of filter attenuation needed. Figure 4.5 shows the noise across the input capacitor ( $C_i$ ) of a boost PFC operating with either fixed or variable frequency. A 10dB noise attenuation is achieved with a modulation depth of 10kHz.

The norms demand the use of a wider bandwidth for noise measurements above 150kHz.; the window is increased from 200Hz to 9kHz. The result is an increased measurement sensitivity at frequencies above 150kHz.

This means that when the switching frequency of a PFC is increased, the effect of low harmonics increases suddenly at 150kHz: they are in effect generating more noise. This fact has to be taken into account when choosing a suitable switching frequency.

In the range 1-30 MHz, the noise is conducted by the parasitic capacitance of the boost inductor. During turn-on switching of the power transistor, the discharge current of this parasitic capacitor can exceed 1A. Using a boost inductor with a low parasitic capacitance can therefore significantly reduce noise and filter cost.

Multi-section winding techniques can be used to produce inductors with low parasitic capacitance, see figure 4.6. When an iron powder core is used, a single layer winding is the best way to achieve a low parasitic capacitance.

Slowing the commutation is also a good means of noise reduction in the range 1-30 MHz. Figure 4.7(a) shows the noise spectrum of a P.F.C. with fast switching and conventional windings. Figure 4.7(b) shows the effects of slowing the commutation, while figure 4.7(c) shows the effects of using multi-section windings.

The parasitic capacitance between the power semiconductors and the heatsink can be kept to a minimum by using insulated packages such as ISOWATT220, ISOWATT218, ISOTOP or DO220I, minimizing asymmetrical filtering.

### 5. CURRENT CONTROL BOOST PFC WITH VOLTAGE FEED-FORWARD

Figure 5 shows a block diagram of a circuit implementing a current control boost PFC. A current reference is obtained by multiplying a number of feedback signals. This current reference is then compared with the average inductor current, and the results of the comparison are fed to the input of the PWM controller.

Figures 4.1 - 4.5

Figure 4.1. Limiting values of interference voltage

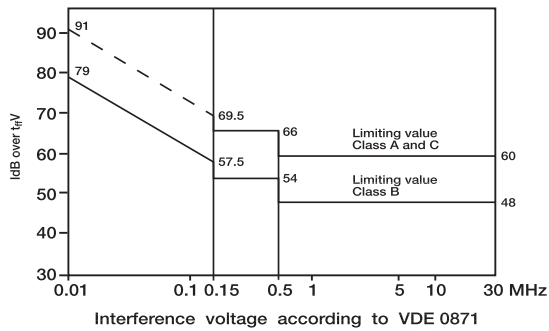

Figure 4.2. Normalized mains impedance

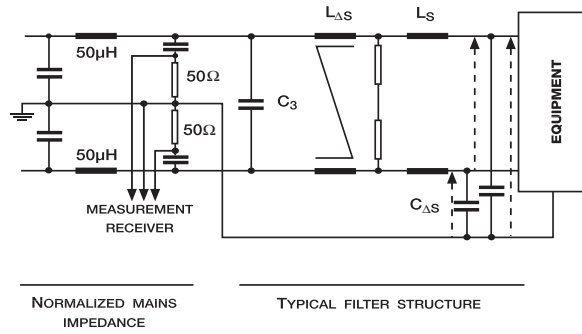

Figure 4.3. Overall filter performance between 30kHz and 150kHz

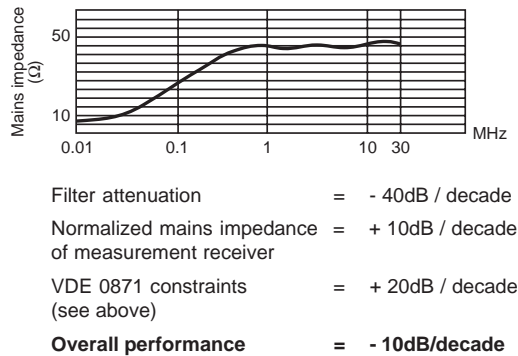

Figure 4.4. Continuous or discontinuous current mode: current ripple amplitude

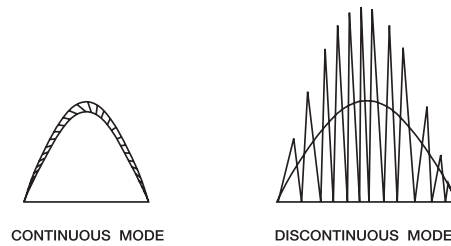
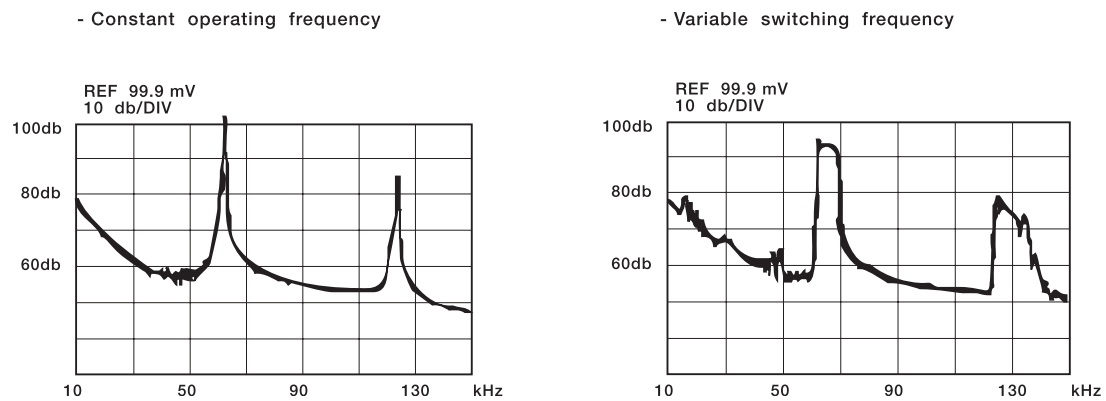

Figure 4.5. Symmetrical interference voltage



Figures 4.6 - 4.8

Figure 4.6. Frequency modulation method

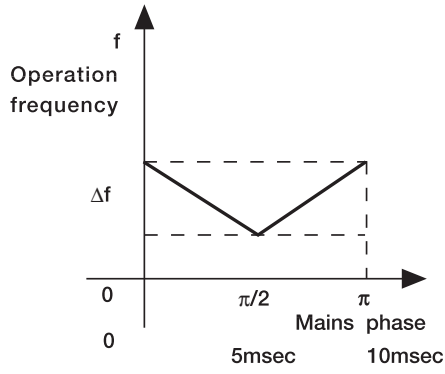

figure 4.7. Winding the Boost inductor

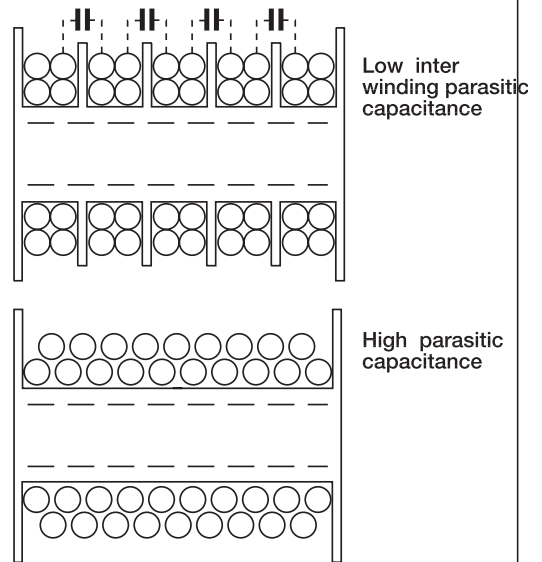

Figure 4.8. High frequency conducted noise

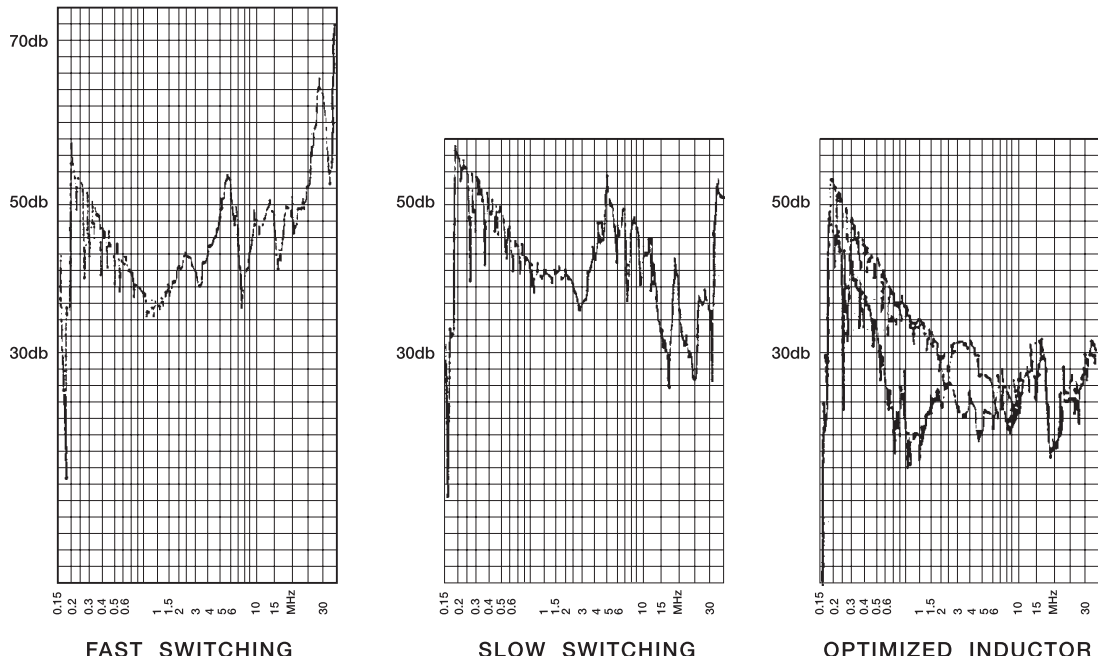
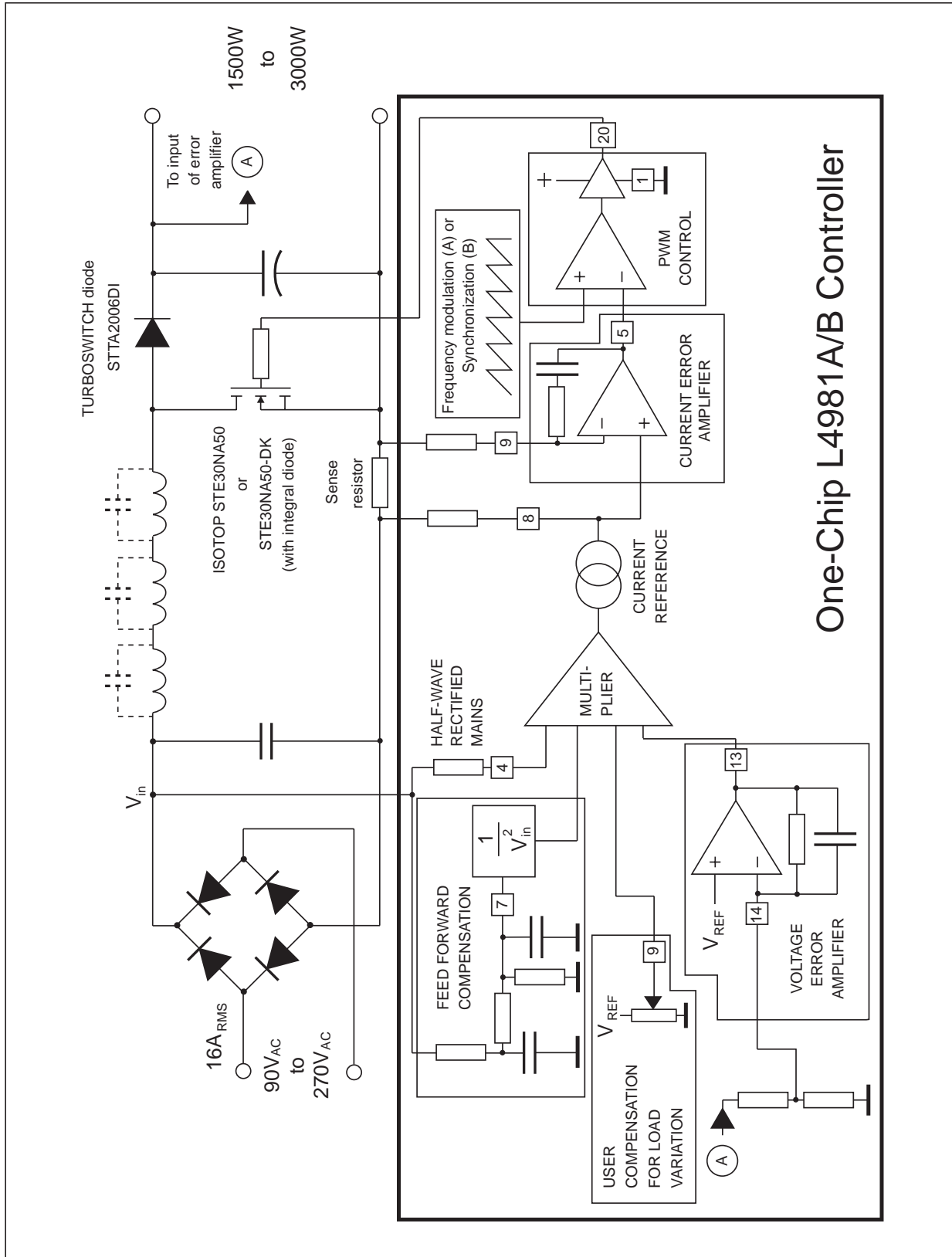

Figure 5. PFCcircuit employing average current control



## APPLICATION NOTE

### 5.1 Operation of the PFC

To operate fully, the power factor corrector must maintain the following conditions:

- 1) The instantaneous value of the current drawn from the supply must follow the instantaneous value of the supply voltage, to ensure that the supply current waveform is sinusoidal and in phase.
- 2) The RMS power drawn from the supply must remain constant even if the the RMS supply voltage varies. This means that if the RMS value of the supply voltage falls, the RMS current drawn must increase.
- 3) The DC output voltage must remain constant despite variations in the load. For example if the DC output voltage falls the current through the load must be increased.

Condition (1) is maintained by feeding a half wave rectified signal at the mains frequency into the multiplier as described in section 1.1, while in certain applications, the voltage error amplifier can compensate for variations in both the RMS supply voltage and in the DC output voltage (as variations in the first lead to variations in the second).

However, in most applications the voltage error amplifier cannot be used to compensate for variations in the input supply voltage. This is because the

output of the PFC is not pure DC - a small amount of ripple still exists on top of the DC signal, which at high levels of voltage and current cannot be eliminated with a realistically sized bulk capacitor. This ripple is at the frequency of the half-wave rectified mains signal, but is slightly out of phase. Hence if it is multiplied with the signal derived directly from the half-wave rectified AC mains, the result is a distorted half sine wave - see figure 6. A low-pass filter must therefore be applied to the input of the voltage error amplifier to remove this ripple. To remove enough of the ripple to allow the error amplifier to operate correctly, this filter usually designed to have a crossover frequency of around 20Hz.

However, the cutoff frequency of this filter decreases with the supply voltage. This is a problem where the value of the supply voltage is not known exactly, or where it is subject to large variations.

As an example, a typical system may be required to operate from a supply where the voltage can vary between 90V and 270V. As the crossover frequency decreases with supply voltage, the filter must be designed for correct operation of the system at the upper voltage limit. If the filter has a crossover frequency of 20Hz at 270V, the frequency will fall to a few Hz at 90V. This means that in this case the error amplifier has an unacceptably slow response to rapid changes of voltage at the input, and large

Figure 6. Distortion of error voltage

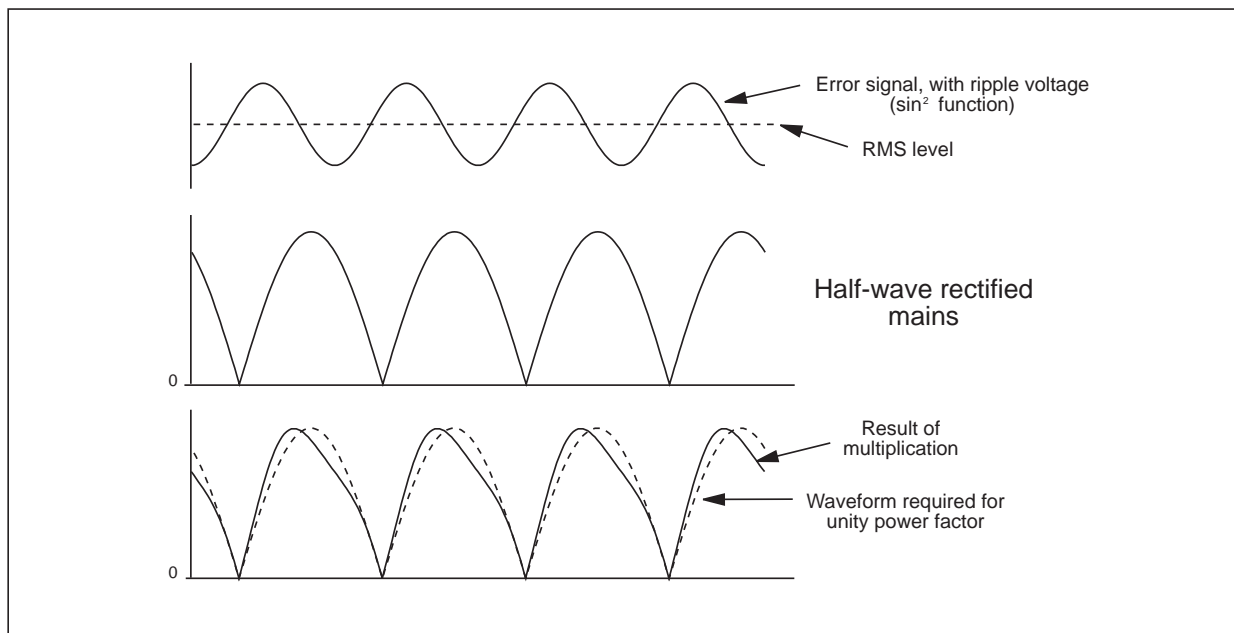



damaging overvoltages may occur on the output.

To account for rapid variations in the supply voltage a signal proportional to the RMS supply voltage must therefore be fed directly from the mains supply at the input. This technique is known as voltage feed forward.

### **5.2 Voltage feed-forward**

The current reference is obtained by modulating the error voltage of the voltage loop with a signal derived from the half-wave rectified mains. The magnitude of this signal should be adjusted such that if the mains voltage doubles (with a constant load), the current reference, and hence the input current, halve. To keep the same voltage error signal requires division of the sinewave modulating signal by four. Using this method, the voltage loop bandwidth is kept constant and voltage overshoot is avoided with varying loads.

### **5.2 Variable frequency operation**

The oscillator can operate at constant or varying frequency. In applications where a varying frequency is used, the noise spectrum can be spread adjusting the depth of modulation using an external resistor. In this way, the maximum inductor current depends upon the minimum operating frequency and there is no asymptote, giving a flat noise spectrum (see figure 4.5). All of these modes of operation are implemented in the L4981 control IC.

## **6. CONCLUSIONS**

Whenever size and cost optimisation are required, a PFC circuit and its input filter must be designed as a whole. PFC circuits generate more noise than a conventional SMPS front end, and their mode of operation and the control techniques strongly influence the filter requirements.

Continuous current mode operation combined with a carefully designed frequency control technique leads to the lowest overall size and cost.

## **REFERENCES**

- 1) "Disturbance in supply systems caused by household appliances and similar electrical equipment"  
EN60555 - European norm
- 2) "Disturbance limitation caused by High Frequency Equipment"  
VDE0871/B
- 3) "Reduction of Electromagnetic Interference - a Power Semiconductor Manufacturer's viewpoint".  
L. Perier - SGS-THOMSON Microelectronics  
Electronique de Puissance Symposium, Paris 1988.
- 4) "Commutation Losses in a High Frequency PWM Converter"  
K. Rischmuller - SGS-THOMSON Microelectronics
- 5) "An AC-DC Converter with Low Mains Current Distortion and Minimized Conducted Emissions"  
M. Albach - EPE Aachen 1989.

## APPLICATION NOTE

---

Information furnished is believed to be accurate and reliable. However, SGS-THOMSON Microelectronics assumes no responsibility for the consequences of use of such information nor for any infringement of patents or other rights of third parties which may result from its use. No license is granted by implication or otherwise under any patent or patent rights of SGS-THOMSON Microelectronics. Specification mentioned in this publication are subject to change without notice. This publication supersedes and replaces all information previously supplied. SGS-THOMSON Microelectronics products are not authorized for use as critical components in life support devices or systems without express written approval of SGS-THOMSON Microelectronics.

© 1997 SGS-THOMSON Microelectronics – Printed in Italy – All Rights Reserved

SGS-THOMSON Microelectronics GROUP OF COMPANIES

Australia - Brazil - Canada - China - France - Germany - Hong Kong - Italy - Japan - Korea - Malaysia - Malta - Morocco - The Netherlands - Singapore - Spain - Sweden - Switzerland - Taiwan - Thailand - United Kingdom - U.S.A.